



Industry solutions for wind turbine generators

Seal, damp and store in a new performance category

Your Technology Specialist

simrit[®]

Simrit, Your Technology Specialist



Simmerring®



Fluid Power



Hydraulic Accumulator



O-Rings



Liquid Silicone Products



Special Sealing Products



Vibration Control

Our unique service package sets standards in quality, functionality and cost effectiveness throughout the industry.

With its comprehensive product range and large number of services, Simrit provides a service package unique in the market for almost every application. Simrit employs its leading technological expertise so that you benefit: We analyse your entire system and fine-tune the individual components to each other in an optimum way. This means you get exactly the solution that best fulfils your requirements – cost effective and dependable. Reinforced by single sourcing, saving time and cost, you will find that Simrit is your ideal partner for all sealing- and vibration-related applications when it comes to complex systems.

We have been the leading experts in materials for decades, and this is a significant factor for success, exceptional performance and continuous technological advancement of our products. Famous product names

such as Simmerring®, Fluid Power, Hydraulic Accumulator, O-Rings or Liquid Silicone Products underpin this. Together with the fields of Special Sealing Products and Vibration Control, they are intrinsically connected with the Simrit brand name and constitute the world's largest product range for all applications throughout industry.

As part of the Freudenberg Group, we draw upon established research, development and production expertise within the Group to continuously extend our technological lead through innovative solutions for the purposes of – and in the service of – our global customers with their local market requirements. The close international cooperation of Simrit in Europe and America with our Japanese partner, NOK, in Asia provides you with consistent quality standards wherever our solutions are required. With Simrit Service Centres in all industrial markets, our global sales network supports you and more than 100,000 other customers dependably and on a basis of mutual trust and cooperation at sites on every continent.

The Simrit service package at a glance:

- **World's largest product range**
Comprehensive solutions from a single source
- **Continuous innovations**
Technological prominence for the competitive advantage of our customers
- **Unique expertise in materials and high quality standards**
Leading know-how for safe and cost-effective applications
- **A huge number of integrated services**
Support from development through to continuous product deployment
- **Globality**
Global expertise with the knowledge of local market requirements



Fresh air for your system efficiency

Our technologies are growing to meet the demands of the wind industry. Simrit's unflinching innovative energy produces solutions to suit the market, like Lube & Seal or Ventoguard™, our latest generation of materials to provide long and uninterrupted system operation.

The technical availability of modern WTG is as high as 98%. The aim of our solutions is not just to maintain these high technical standards in the long term and to maintain them efficiently, but to improve them even further. That is why Simrit offers services tailored to market needs, for everything from system advice across all relevant applications to high-performing all-in-one solutions, for a complete main transmission, for example.

Service life protection

Longer service life thanks to innovative technologies: our globally sought-after expertise in development of materials coupled in the development, testing and manufacturing facilities of the Freudenberg group are the basis for exceptionally reliable technologies that function day after day. Ventoguard™ is the latest generation of materials that Simrit has developed especially for the wind industry. The new Ventoguard™ 453, for example, is particularly resistant to weathering, lubricating grease, air with a high salt content and ozone, fitting the bill exactly for use in pitch and yaw bearings in wind turbines.

The results of our comprehensive system analysis constantly lead to new, improved solutions that safeguard your system.

With Lube & Seal, Simrit and its sister company, Klüber Lubrication, offer a globally unique technology service to optimise the sealing material and lubricant. Lube & Seal can significantly increase the service life of seals – and with it the reliability of main, pitch, yaw and transmission bearings.

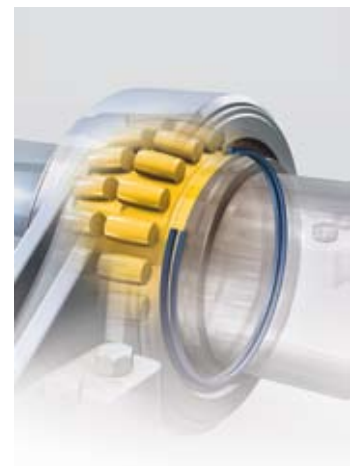

LUBE  **seal**

Improved performance

Greater performance with Simrit: re-dimensioned WTG in the highest performance categories require optimum sealing technology. Simrit is there with you from the beginning as a competent development partner for your upscaling projects. With applied FEM simulations and extensive testing and analysis facilities, we can design sealing solutions to fit your demands exactly. Such early collaboration saves time and ensures mature, reliable products from commissioning onwards.



Increase technical availability

Simrit helps to minimise downtimes: every downtime for unplanned repairs and maintenance costs time and money. Downtimes for sealing repairs can be avoided and maintenance times reduced using our mature Condition Monitoring technology for remote monitoring of sealing functions. If the worst comes to the worst, you will get rapid assistance direct from Simrit. We can provide turned seals within 24 hours if necessary, using Merkel Xpress. With the reusable gluing kit RK 15 for Radiamatic Simmerrings, seals can be exchanged instantly without disassembling the shaft.

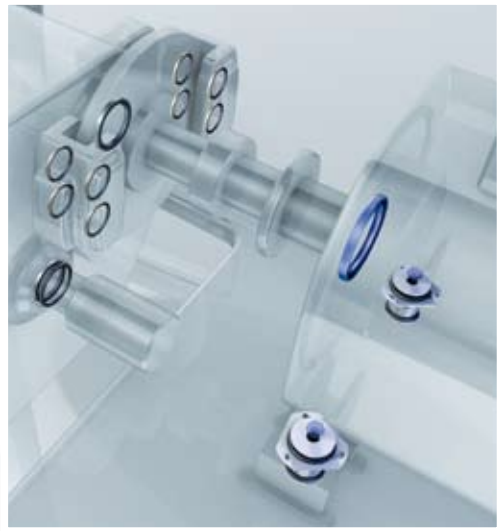
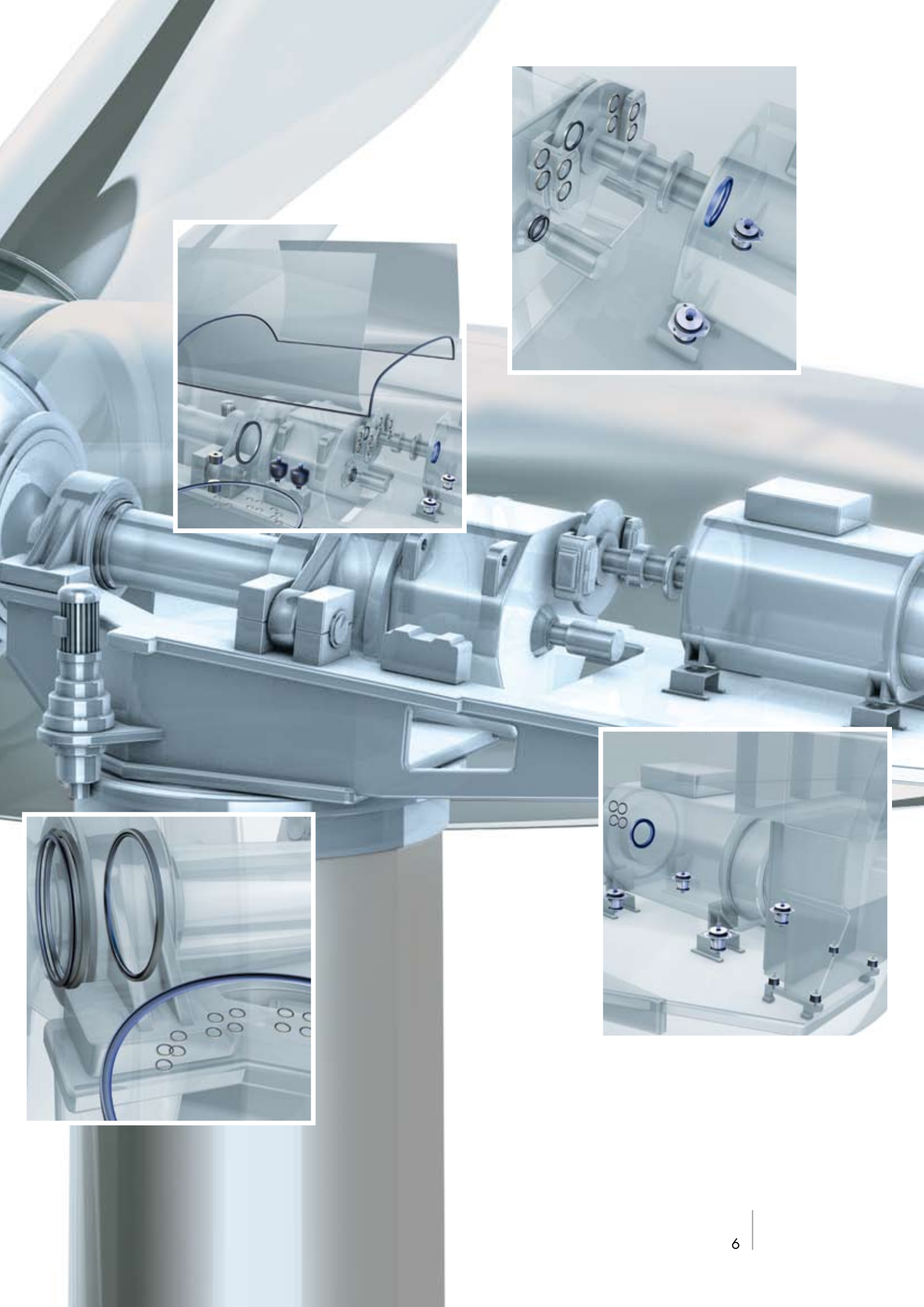

Simrit all-in-one solutions for WTG

Seal, damp and store – Simrit’s all-in-one solutions offer reliable technology to a consistently high standard for all applications in your WTG.

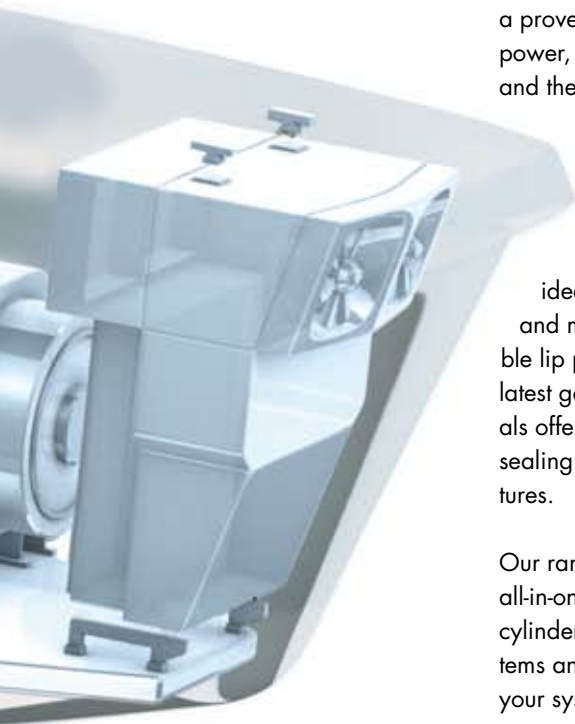

Simrit Sealing Technology

As a leading global supplier of sealing technology, Simrit gives you a unique range of sealing products: in addition to the original Simmerring, the R35 (up to 3,500 mm in diameter) with a proven track-record in wind power, the low-friction HTS II and the innovative labyrinth seal, Radiamatic RCD, make excellent sealing results a reality in your main gears and bearings, thanks to an ideal combination of design and material. Single and double lip profiles made from the latest generation of NBR materials offer a particularly reliable sealing function at low temperatures.

Our range is rounded off by all-in-one solutions for hydraulic cylinder pitch adjustment systems and brakes to safeguard your systems.

Simrit Vibration Control Technology

Our vibration control technology components meet the most exacting requirements for vibration damping and sound insulation. Conical mounts, round mounts, ultra bushes, MO and V mounts offer real protection for components and adjacent devices against wear and damage, and increase the service life of your systems.

Simrit Hydraulic Accumulators

Indispensable in every WTG, Simrit hydraulic accumulators for hydraulic pitch control and brake systems offer constant and uninterrupted pressure. Our membrane reservoirs, piston accumulators and bladder accumulators operate and function reliably in pressure ranges up to 350 bar and at temperatures from -40 to $+140$ °C – an absolute must to ensure your system has enough energy to handle peaks in demand and reserves for emergencies.

Totally covered – with Simrit, you will find innovative solutions for all your WTG systems, consolidated in a unique product portfolio for:

- Drives
- Brakes
- Generators
- Transmissions
- Couplings
- Ball and Roller Bearings
- Hydraulic components
- Rotor blades
- Nacelles and hatches
- Control elements
- Tower
- Supporting cross pieces

Innovative industry solutions for a better system performance



With its tailored technologies, Simrit offers comprehensive know-how for reliable and high-performing wind turbine generators (WTG).

The wind industry today is one of the fastest growing industries with continuously rising energy production – and demand is continuing to grow at a rapid pace.

WTG manufacturers, component suppliers and operators face sophisticated system efficiency problems if they are to achieve a maximum increase in returns with long service life and minimum downtimes.

As one of the world's leading technology specialists, Simrit has designed its range of services for the wind industry to fit requirements exactly and provides technologies to safeguard your system comprehensively – and increase efficiency. The range of applications includes

solutions for everything from rotor main mountings, pitch and yaw mountings and customised hydraulic sealings for braking systems and pitch adjustment systems to components for gears and auxiliary aggregates such as control units, and for all key areas of a WTG that require particularly reliable sealing, vibration control or storage technology.

Comprehensive systems expertise for market-oriented solutions

Our solutions for sealing, dampening and energy storage are the result of extensive market and systems expertise. That means that, before a Simmering or a hydraulic accumulator gets to you, we look very carefully at how our technologies can optimise your system performance most effectively. As a result, we create the perfect conditions for high power output with as little interruption of system operation as possible – throughout the system's service life of 20 years or more.

Simrit all-in-one solutions for WTG

More reliability and greater service life for all systems in the WTG – Simrit all-in-one solutions cover all sealing, vibration and storage applications in your system at a consistently high level of quality. But we think even further ahead: innovative services to standardise sealing materials and lubricants along with the integration of Condition Monitoring functions offer new opportunities to increase system reliability.

www.simrit.com

Simrit Americas

Plymouth, Michigan, USA
Tel: +1 (866) 274 6748
Fax: +1 (734) 354 5500
E-mail: information@simrit.us

Simrit Europe

Weinheim, Germany
Tel: +49 (0) 18 05 - 74 67 48
Fax: +49 (0) 18 03 - 74 67 48
E-mail: info@simrit.de

Simrit China

Shanghai, China
Tel: +86 (21) 50 36 - 69 00
Fax: +86 (21) 50 36 - 63 07
E-mail: simrit@nfgc.com.cn

simrit[®]